

Wichtig: Wenn Sie kein ausgebildeter Mechaniker sind, wenden Sie sich bitte an eine Fachwerkstatt.

Bitte unbedingt vor dem Anbau beachten!

Die Montage der Crash-Pads muss seitenweise erfolgen! Das gleichzeitige Lösen der beiden Motorhalteschrauben ist zu vermeiden! Anzugsdrehmomente lt. Herstellerangaben!

Für das Bohren der beiden Verkleidungshälften die beiliegende Schablone verwenden!

Anbau der rechten Seite:

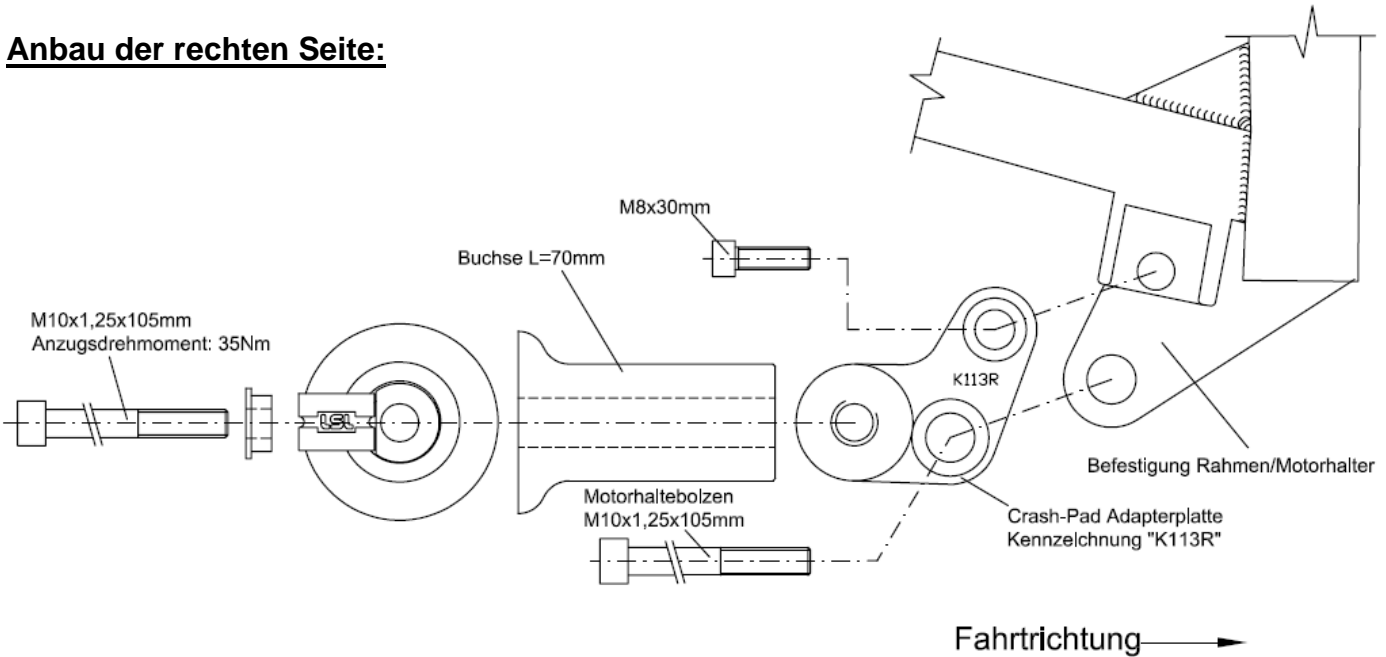

Anbau der linken Seite:

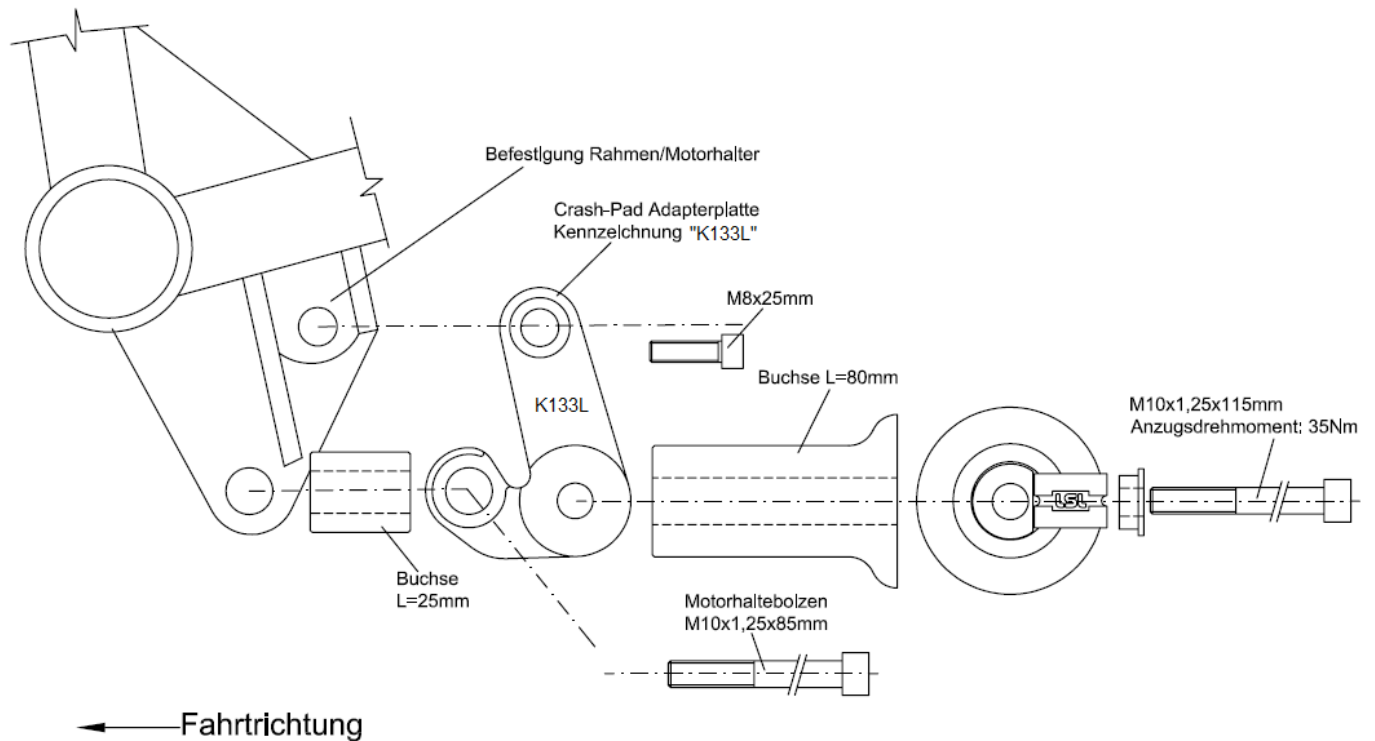

Achtung: Beide Verkleidungsseitenteile anzeichnen, klein vorbohren und prüfen, ob Bohrungen und Montagepunkte fluchten!

Rechtes Seitenteil:

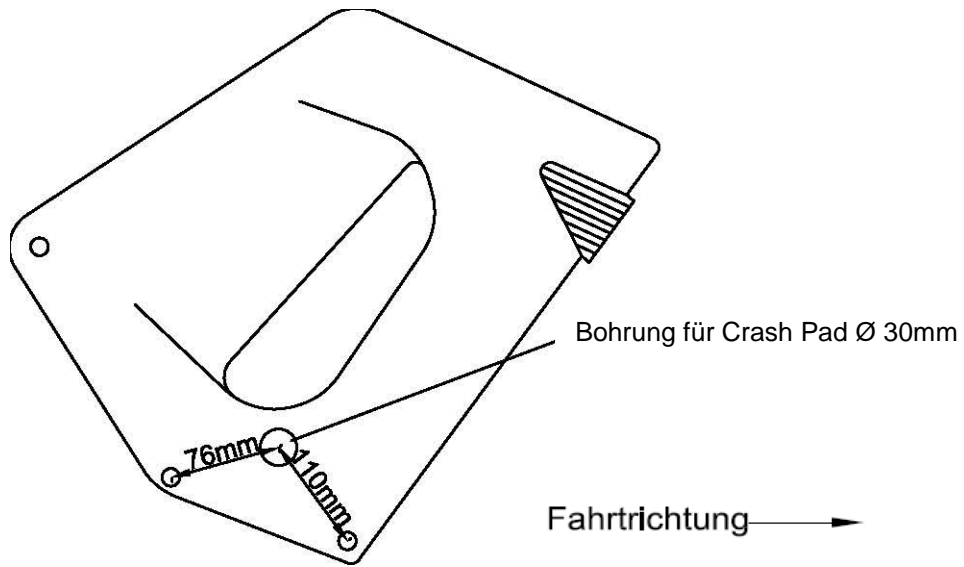

Linkes Seitenteil:

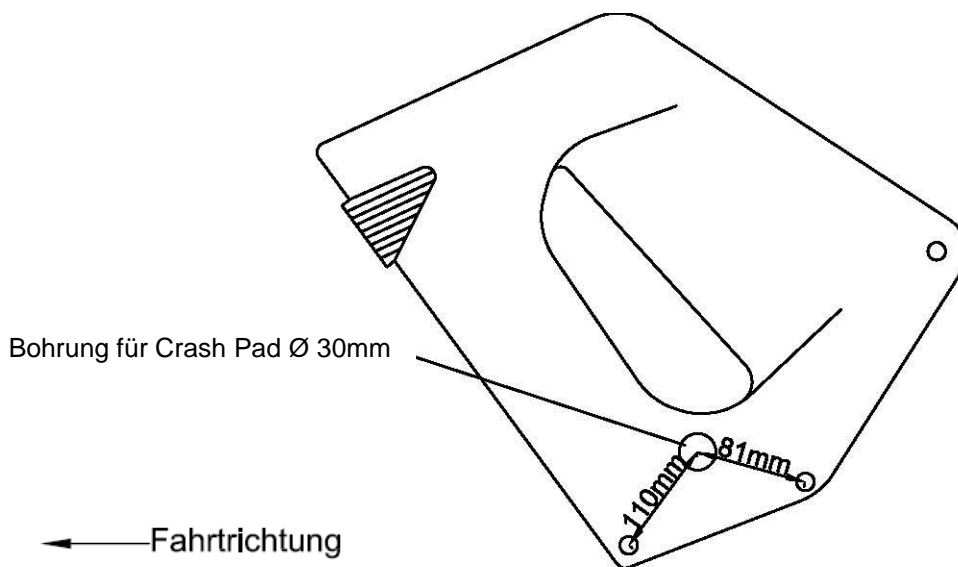

Important: If you are not a trained motorcycle mechanic stop now.
Ask a local motorcycle shop to do the work for you.

Please take extra care!

You have to mount the crash-pads one side after the other!
Do not loose more then one engine mounting bolt at the same time!
The tightening torques refer to the manufacturer´s instructions!
The cowling has to be modified, use the drilling template!

Fitting of the right side:

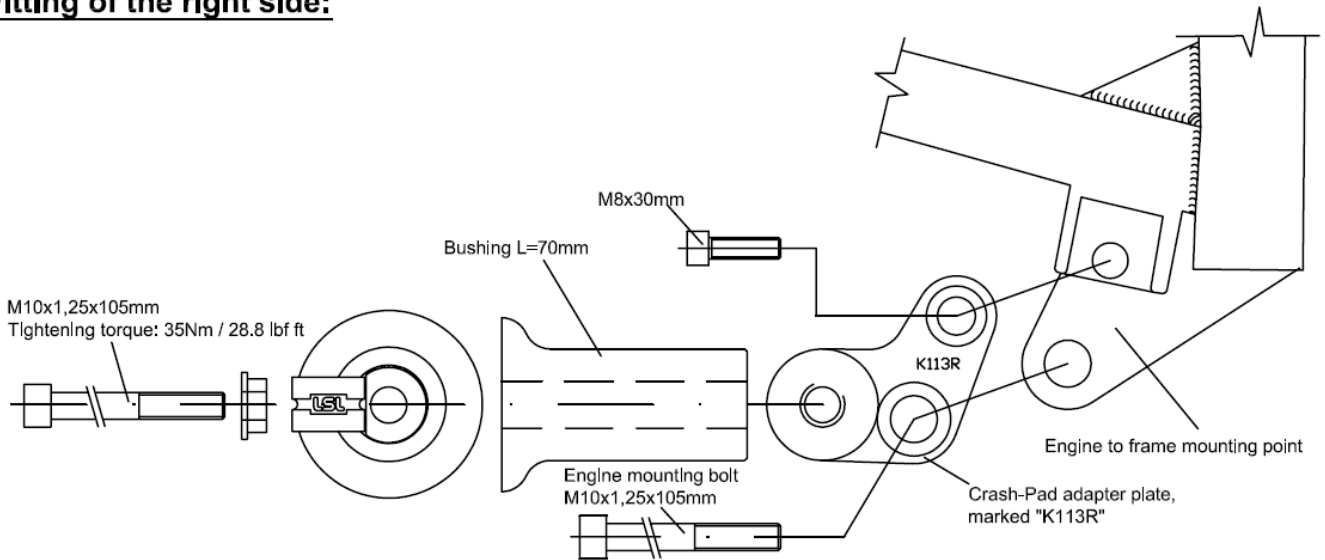

Fitting of the left side:

Driving direction →

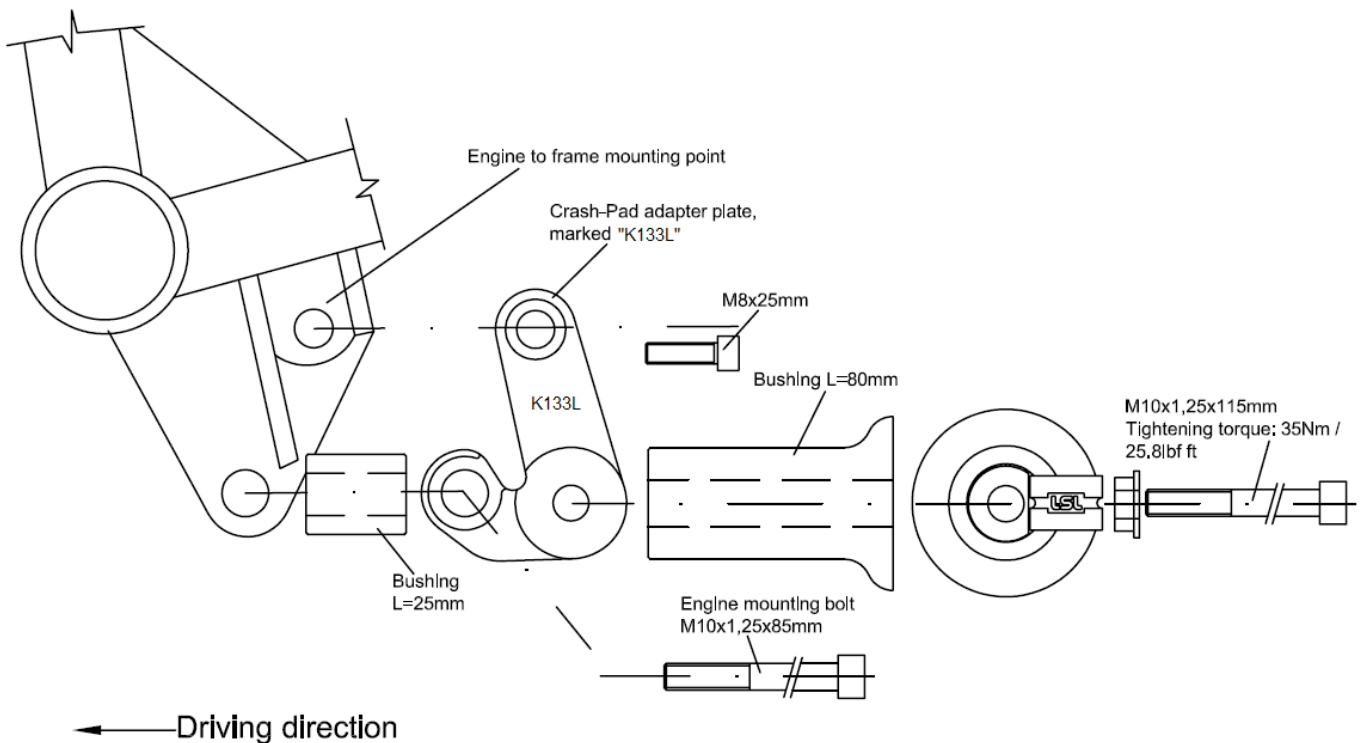

LSL-Motorradtechnik GmbH · D-47809 Krefeld

www.lsl.eu

Attention: Mark both fairing parts and drill small bores first to check the alignment of bores and mounting points.

Right side

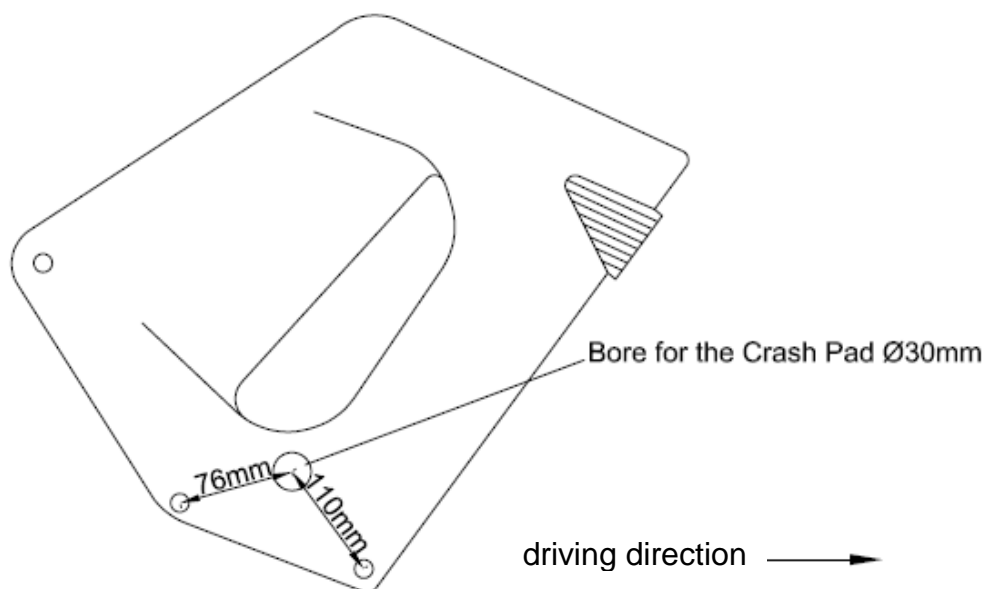

Left side

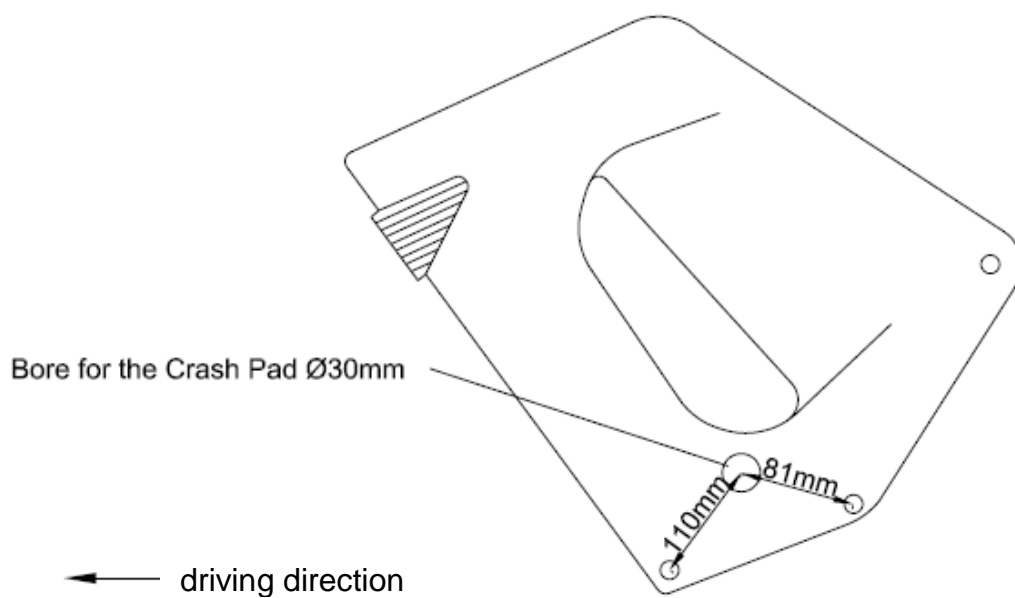

Instructions de montage des Crash-Pads pour Kawasaki ER-6f 2006 → N° article : 550K117

Important: Le montage doit être fait par un professionnel!

Le montage des Crash-Pads s'effectue d'abord d'un côté et ensuite de l'autre! Il faut éviter le desserrage simultané des deux vis tenant le moteur!
Utilisez les couples de serrage préconisés par le constructeur!

Montage côté droit:

(Vue arrière)

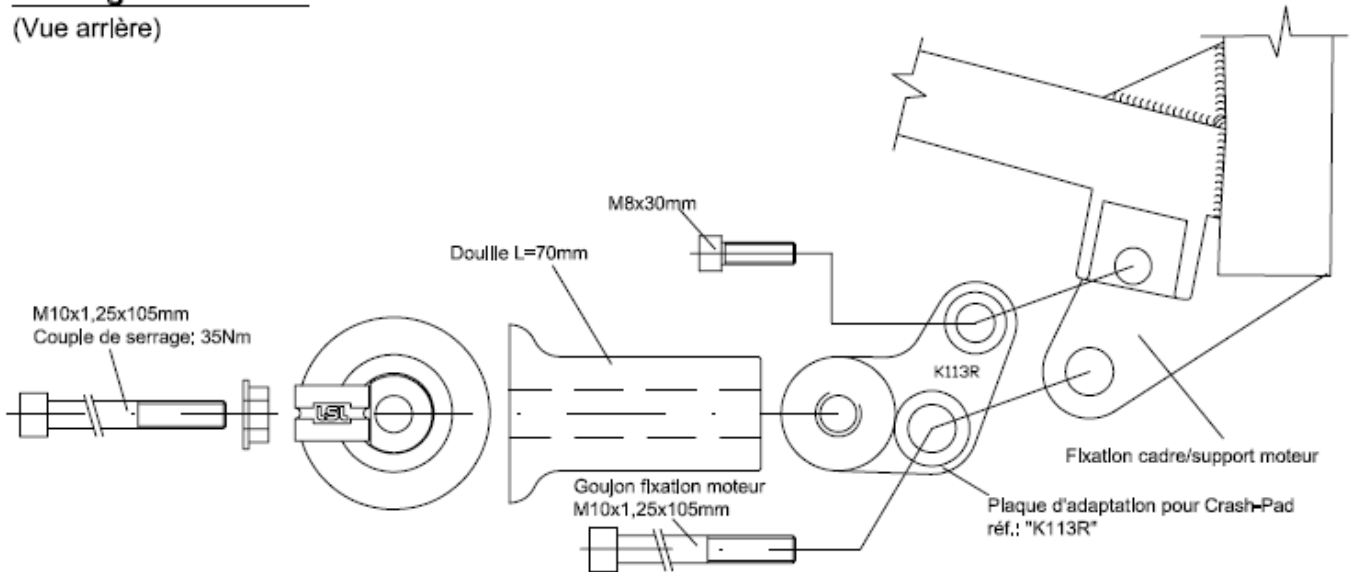

Montage côté gauche:

(Vue arrière)

Sens de la marche →

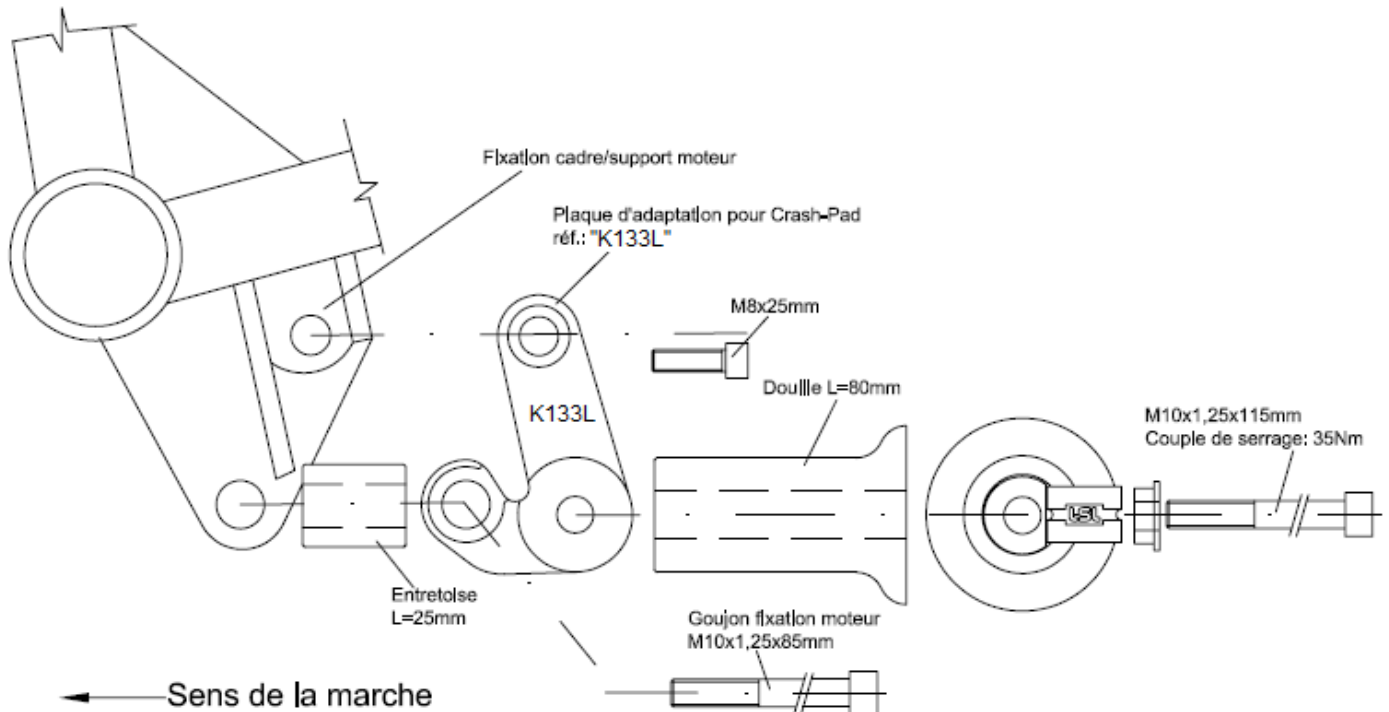

LSL-Motorradtechnik GmbH • D-47809 Krefeld

www.lsl.eu

Schéma de perçage des Crash- Pads pour Kawasaki ER-6F `06-
N°art.: 550K117

Attention: Positionner les points de perçages, percer de petits trous et vérifier s'ils correspondent aux points de montage avant de les agrandir!

Partie latérale droite

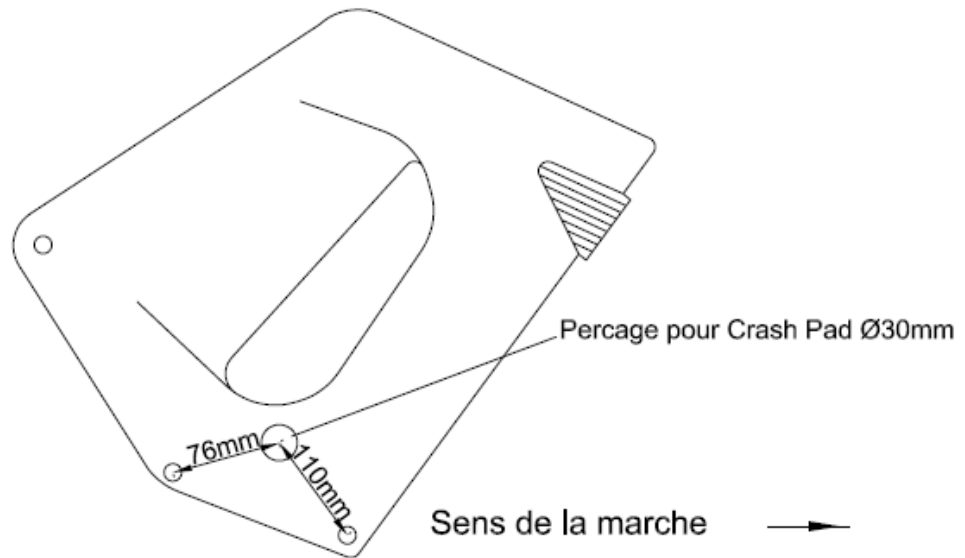

Partie latérale gauche

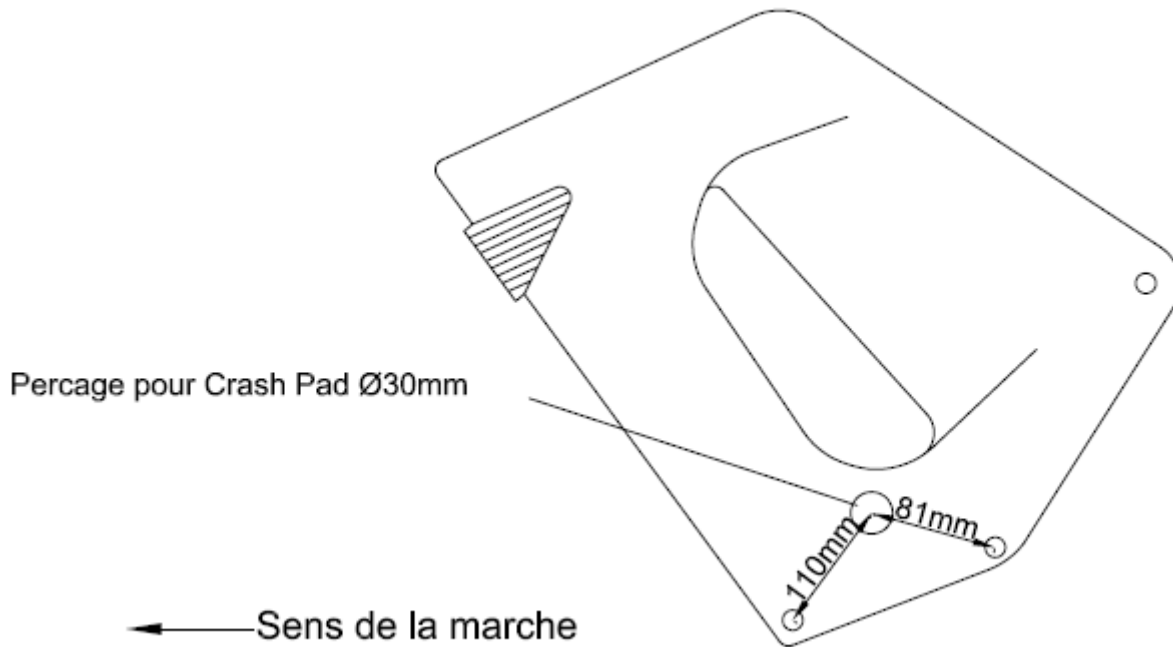

LSL-Motorradtechnik GmbH • D-47809 Krefeld

www.lsl.eu