

Wichtig: Wenn Sie kein ausgebildeter Mechaniker sind, wenden Sie sich bitte an eine Fachwerkstatt.

Bitte unbedingt vor dem Anbau beachten!

Die Montage der Crash-Pads muss seitenweise erfolgen!

Das gleichzeitige Lösen der linken und rechten Motorhalteschrauben ist zu vermeiden!

Anzugsdrehmomente lt. Herstellerangaben!

Anbau der rechten Seite

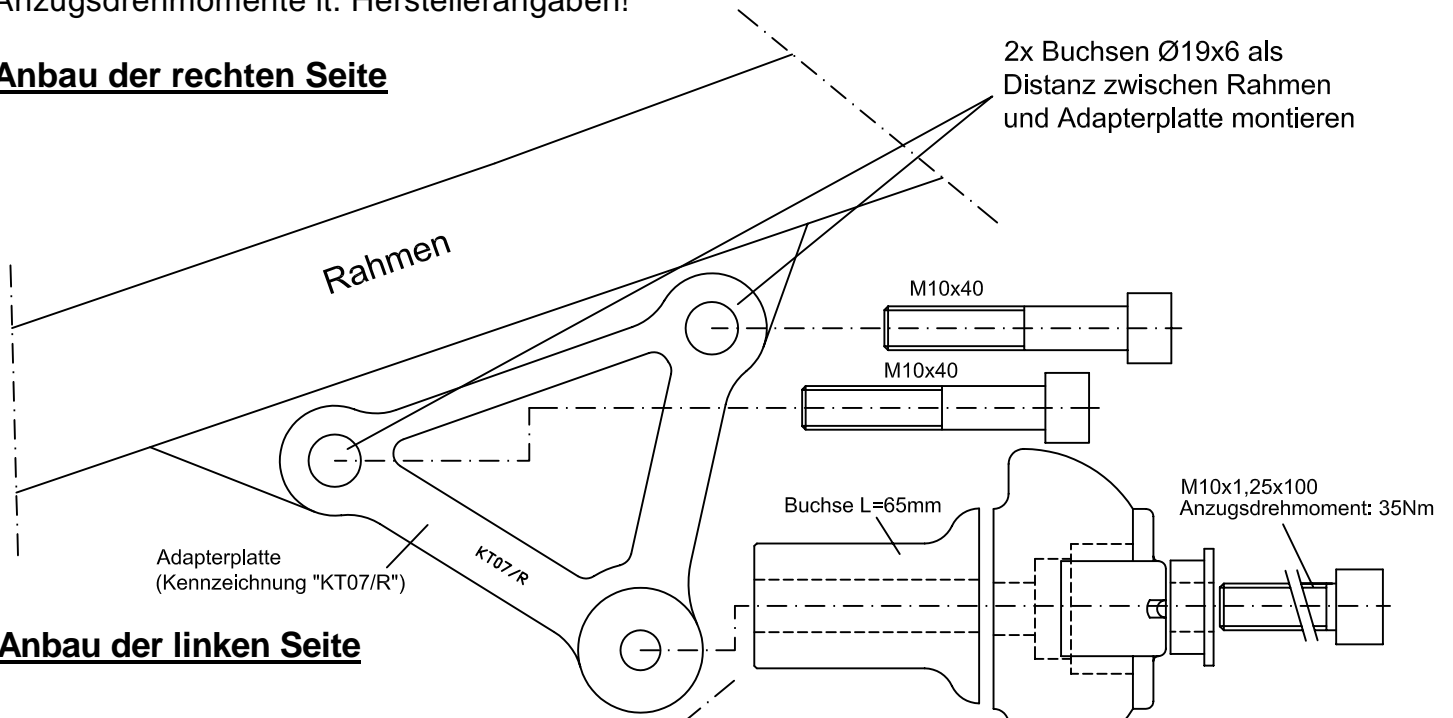

Anbau der linken Seite

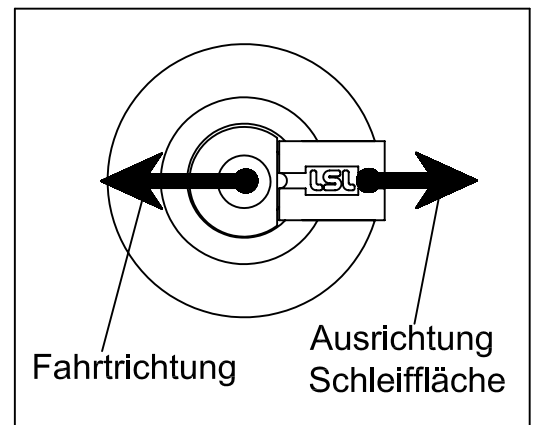
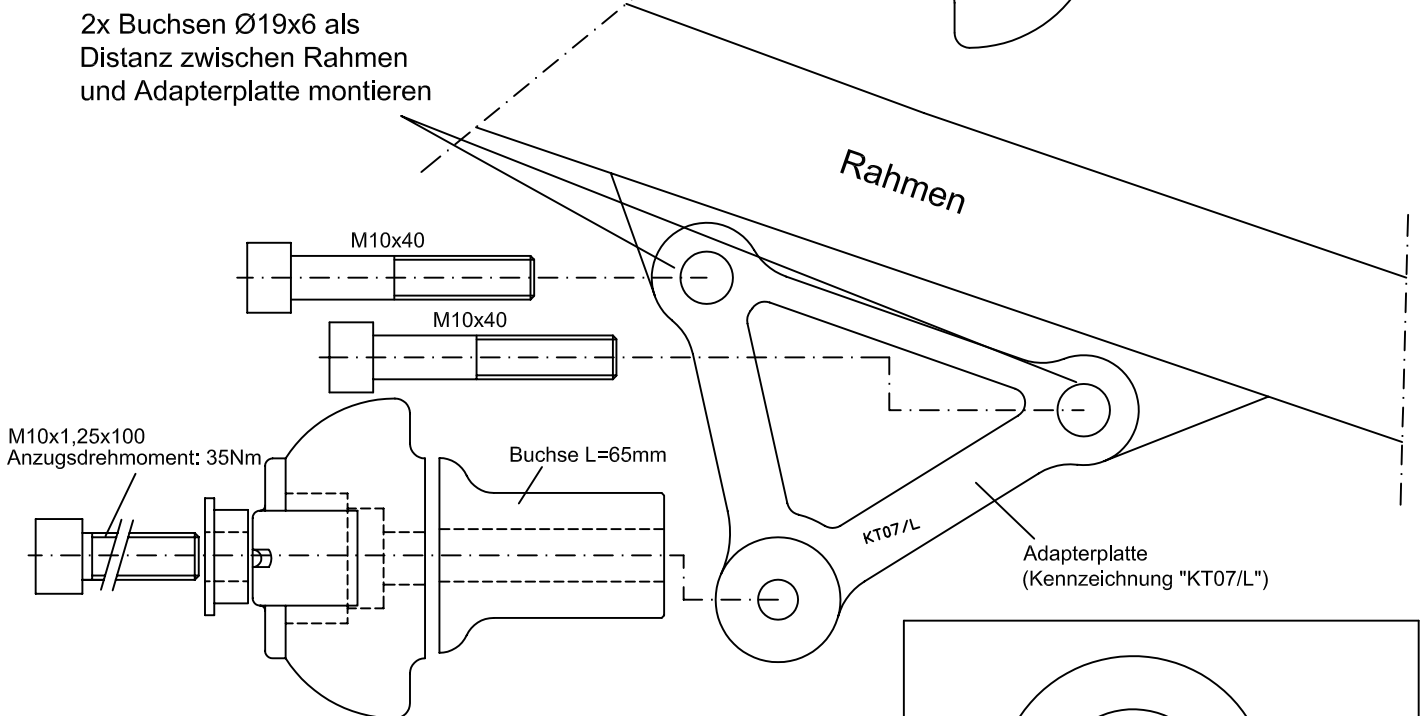

Important: If you are not a trained motorcycle mechanic stop now. Ask a local motorcycle shop to do the work for you.

Please take extra care!

You need to mount the Crash-Pads one side after the other! Do not loose more than the two engine mounting bolts on one side at the same time!

The tightening torques refers to the manufacturer's instructions!

Fitting on the right side:

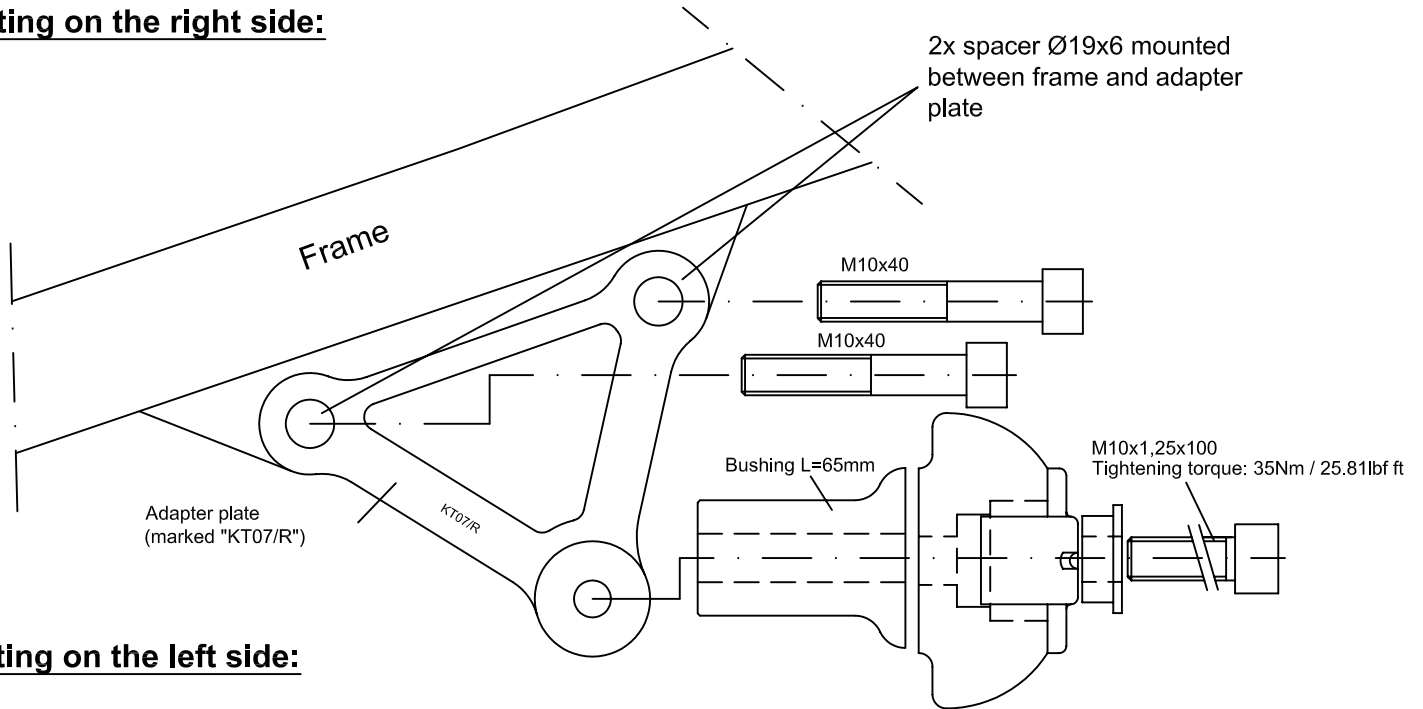

Fitting on the left side:

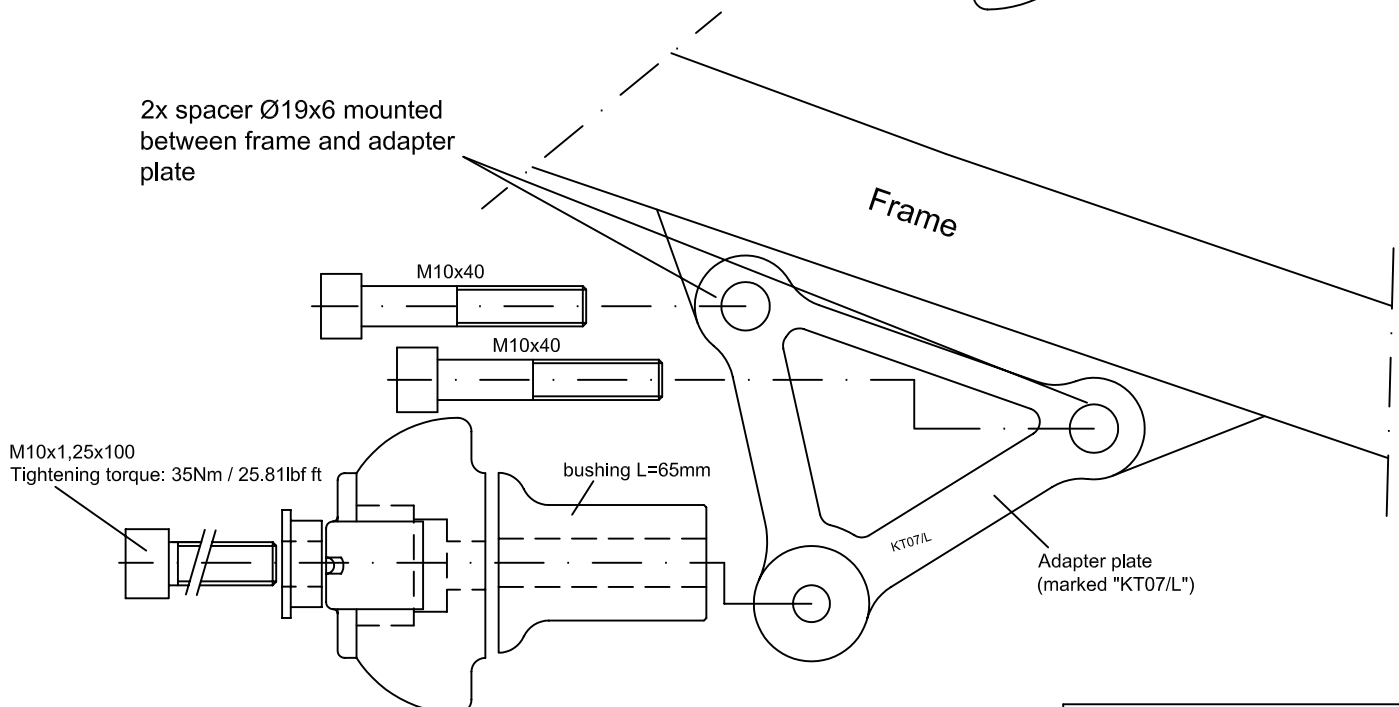

LSL-Motorradtechnik GmbH • D-47809 Krefeld

www.lsl.eu

Rev. 00 21/08/2009

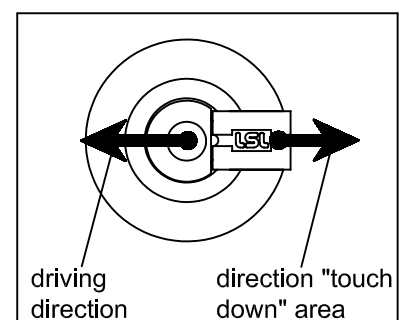

Instructions de montage des Crash-Pads pour KTM SMT 990 '09→

N° article : 550KT10.1

Important: Le montage doit être fait par un professionnel!
Le montage des Crash-Pads s'effectue d'abord d'un côté et ensuite de l'autre! Il faut éviter le desserrage simultané des deux vis tenant le moteur!
Utilisez les couples de serrage préconisés par le constructeur!

Montage côté droit:

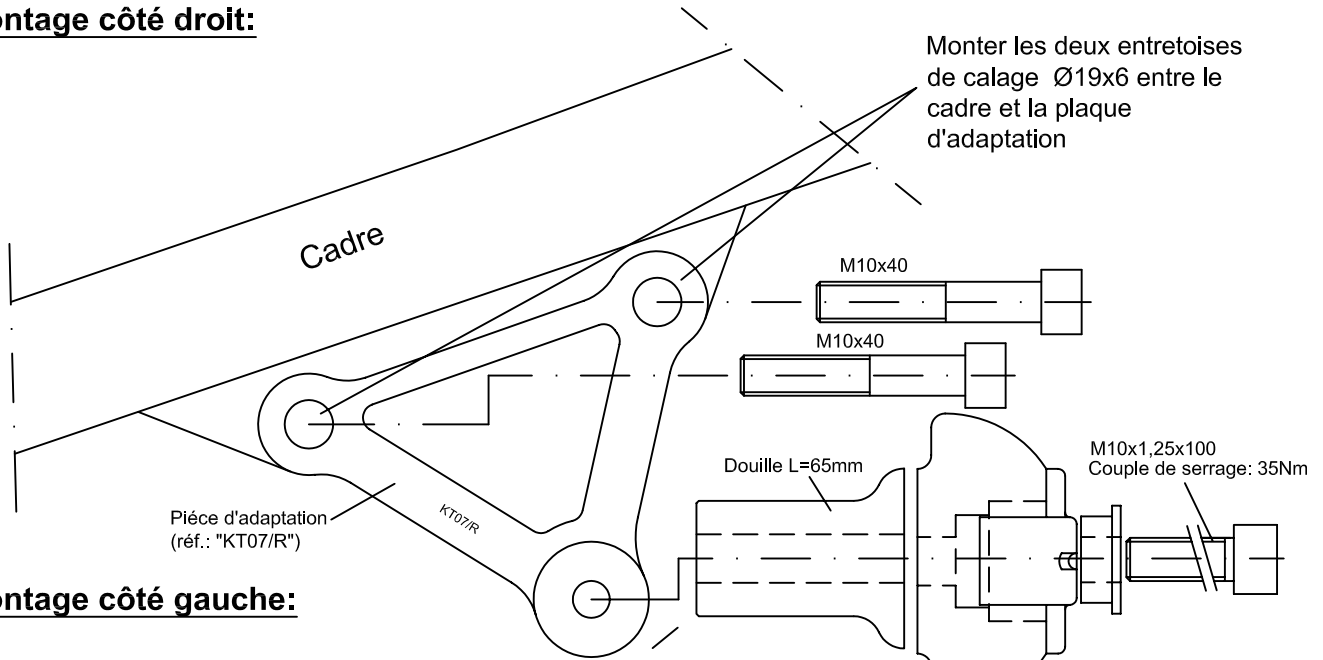

Montage côté gauche:

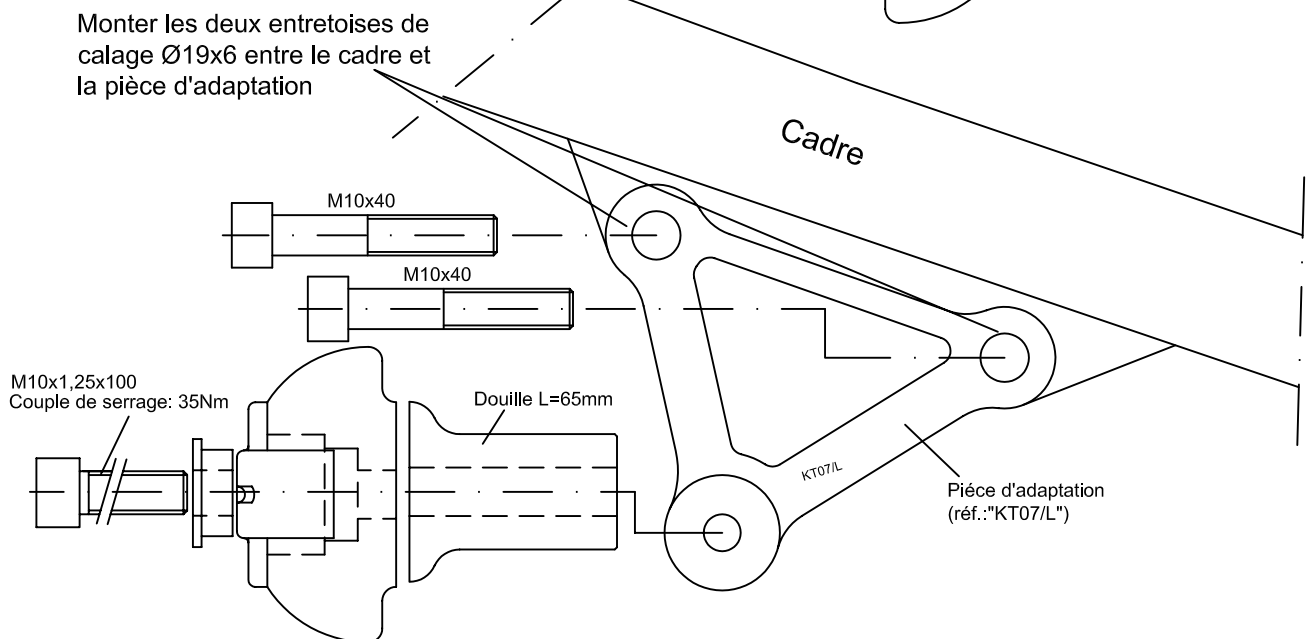

LSL-Motorradtechnik GmbH • D-47809 Krefeld

www.lsl.eu

Rev. 00 21/08/2009

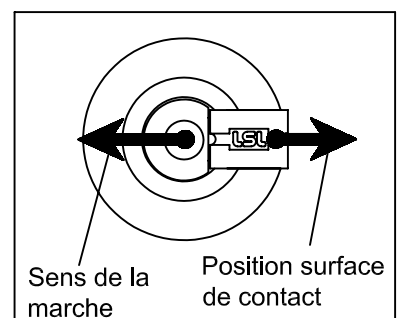



LSL-Motorradtechnik GmbH • D-47809 Krefeld

www.lsl.eu